

BALANCED RECEIVER EXTERNAL MODULATION FIBER-OPTIC LINK ARCHITECTURE WITH REDUCED NOISE FIGURE

E. Ackerman, S. Wanuga, J. MacDonald, and J. Prince

GE Electronics Laboratory, Syracuse, New York

ABSTRACT

We describe a fiber-optic link architecture which minimizes noise figure by combining the two complementary outputs of a Y-fed coupler electro-optic modulator in such a way that the optical noise cancels in a balanced receiver module. The demonstration link exhibits 9.5 dB insertion loss and 13.5 dB noise figure at 900 MHz.

INTRODUCTION

Optical fiber is an ideal T/R module or subarray interconnect because it is very small—nominally 125 μm in diameter—resulting in less waveguide congestion at a phased array backplane. Glass fiber is rugged and flexible, with negligible weight, tensile strength greater than 10^6 lb/in², and minimum bend radius less than 1 inch. It is virtually transparent (attenuation is typically <0.5 dB/km), even to light modulated at frequencies up to 100 GHz. The replacement of a metallic waveguide system with a fiber optic network also imparts immunity to interference (EMI and EMP) and typically >100 dB isolation from signal crosstalk.

Moreover, the transparency, small size and enormous bandwidth of the optical waveguide render it an attractive medium in which to perform true-time-delay phase shifting for phased array beamforming, because signals will incur nearly the same loss in the shortest delay line as in the longest. This combination of benefits has motivated several researchers to develop novel photonic beamforming architectures [1-5].

Most modern phased array radars have stringent dynamic range requirements. Crucial to the success of optical beamforming, therefore, is the realization of photonic links capable of routing microwave signals with minimal signal-to-noise ratio degradation (noise figure).

Directly modulated semiconductor lasers may serve as both the optical source and electro-optic modulator in a fiber-optic link and therefore have size and cost advantages compared to modulating a laser's output power with a separate external modulator. Unfortunately, the relative intensity noise of semiconductor lasers is greater than that of most other solid-state lasers at microwave frequencies. Links in which integrated optical devices externally modulate light from solid-state laser sources have therefore exhibited broader dynamic range than direct modulation links.

Even in state-of-the-art external modulation links, however, noise figure exceeds 20 dB at frequencies of 1 GHz or more. Figure 1 shows the reported noise figures of several external modulation fiber-optic links demonstrated at frequencies ranging from 60 MHz to 20 GHz [6-13].

The total noise power at the output of any low-loss fiber-optic link is dominated by the optical source's noise contribution. Therefore, if this optical noise could be reduced or cancelled completely, the link's dynamic range and noise figure would both improve dramatically. In this paper, we describe a balanced receiver external modulation link architecture which minimizes noise figure by combining the two complementary outputs of a Y-fed coupler electro-optic modulator in such a way that the signal power is increased while the detrimental effect of the optical noise is substantially negated.

LINK ARCHITECTURE

Figure 2 shows the link architecture, which is similar to one described by Madjar and Malz [14], except for our use of a Y-fed coupler modulator with complementary optical outputs in place of their optical power divider and single-output modulator.

The balanced receiver module uses identical reverse-biased p-i-n photodiodes to convert the two incoming optical noises to identical photocurrents. From an RF standpoint, the capacitors provide a



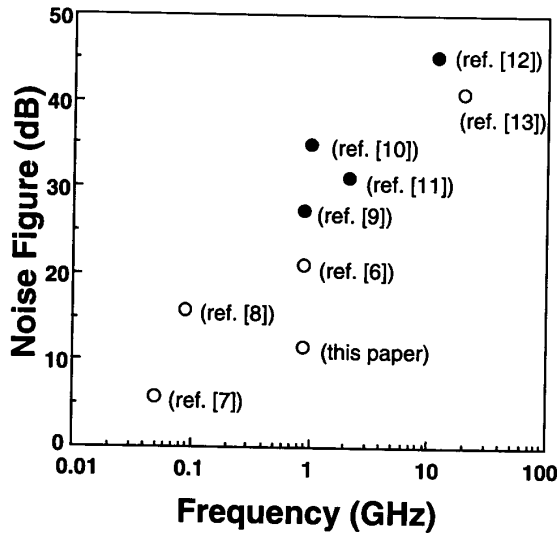

Figure 1 Published noise figure results for several state-of-the-art fiber-optic links [5-12]. Black circles indicate direct modulation links, and white circles indicate external modulation links. The measured noise figure of the link described in this paper is included for comparison.

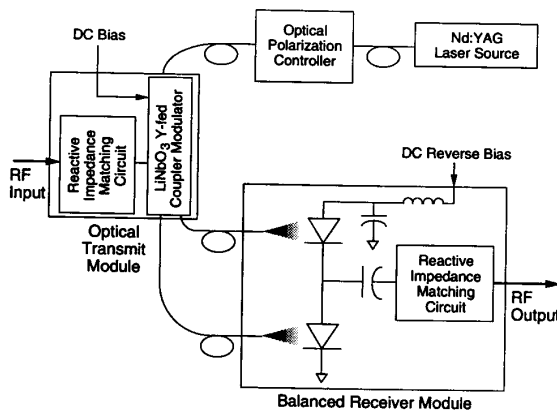

Figure 2 External modulation link architecture which employs the Y-fed modulator and a balanced receiver for cancellation of the optical noise.

short circuit and the inductor provides an open circuit. If the two modulator output fibers are equal in length (to within a few percent of a microwave wavelength), these photocurrents are equal in amplitude but 180° out of phase at their connection point [15].

The optical carriers in the two fibers must be RF-modulated 180° out of phase relative to one another to prevent the modulation from cancelling

(along with the optical source noise) in the balanced receiver. We used a symmetric Y-fed coupler electro-optic modulator that accomplishes RF modulation of a $\lambda=1.3 \mu\text{m}$ optical carrier in this manner. At any modulation frequency, the RF-modulated optical signals in the two output fibers are 180° out of phase.

NOISE RELATIONSHIPS IN THE BALANCED RECEIVER MODULE

The optical relative intensity noise (RIN) incident upon both detectors is from the same source; therefore, the two detector photocurrents proportional to laser RIN—defined here as $i_{\text{RIN},1}$ and $i_{\text{RIN},2}$ —are correlated. At the point where the two detectors are connected in series, the spectral current density of the photocurrent due to laser RIN is therefore:

$$\langle i_{\text{RIN, total}}^2 \rangle = \langle i_{\text{RIN},1} + i_{\text{RIN},2} \rangle^2. \quad (1)$$

For a perfectly symmetric y-fed coupler modulator and a perfectly balanced receiver, $i_{\text{RIN},2} = -i_{\text{RIN},1}$, and thus the total spectral current density due to laser RIN is zero.

Thermal noise remains a factor in the total noise output of the link, as does the quantum (shot) noise generated by the uncorrelated photodetection processes at the two detectors in the balanced receiver. The total spectral current density of the shot noise at the connection point is:

$$\langle i_{\text{shot, total}}^2 \rangle = \langle i_{\text{shot},1} \rangle^2 + \langle i_{\text{shot},2} \rangle^2 = 4q(I_{\text{DC}} + I_{\text{dark}}), \quad (2)$$

where q , I_{DC} , and I_{dark} are, respectively, the electronic charge, the DC photocurrent and the dark current generated by the detectors.

BALANCED RECEIVER FIBER-OPTIC LINK: EXPERIMENTAL RESULTS

To demonstrate the link depicted in Figure 2, we selected a LiNbO_3 y-fed coupler modulator with only 2.3 dB optical insertion loss between the input fiber and either output fiber, and >26 dB on/off extinction ratio in each fiber. We measured a 5 V difference between the voltage settings required to direct the optical output fully into fiber 1 and fully into fiber 2.

The balanced optical receiver was constructed by connecting the p and n contacts of two InGaAs ($\lambda=1.3 \mu\text{m}$) p-i-n photodiodes in the configuration shown in Figure 2. Two single-mode fiber pigtailed of equal length were then precisely aligned to these detectors.

Optical source power of 40 mW was obtained from a Nd:YAG ($\lambda=1.3 \mu\text{m}$) laser with a single-mode optical fiber pigtail. We spliced this fiber and the two balanced receiver fiber pigtails to the modulator's input and output fibers, respectively. Using an optical fiber polarization controller, the orientation of the field launched into the modulator's polarization-maintaining input fiber was adjusted to maximize the extinction ratio between the two output fibers. This also resulted in minimum insertion loss.

Double-stub tuners were used to reactively match the 50Ω input of the link to the impedance of the modulator electrodes at 900 MHz. The parallel combination of the two reverse-biased p-i-n photodiode detectors were similarly matched to the link's 50Ω output to minimize reflection losses and maximize the transducer gain in the balanced receiver. Using an HP automatic network analyzer we measured 900 MHz return losses of 36 dB and 27 dB at the optical transmitter input and balanced receiver output, respectively.

Shown in Figure 3 is the link gain and noise figure we measured using an HP noise figure meter. The gain peaked at about -9.5 dB near 900 MHz, where the noise figure was at its minimum value of 13.5 dB. This is among the lowest published noise figure measurements for fiber-optic links at any frequency, and is an improvement of almost 10 dB relative to any result at or above this frequency, as illustrated in Figure 1.

CONCLUSIONS

We will be able to determine how closely we approached the limits of the noise performance (dictated by shot noise) once we have developed a valid analytical model of the modulator and balanced receiver circuit in this link. Depending upon the relative strengths of the various sources of noise in the link (thermal, shot, and any uncanceled laser RIN), it may be possible to obtain the same noise figure using a semiconductor laser as the optical source. Such a substitution would dramatically decrease the cost of the link. Furthermore, this would decrease the size and thus make it possible to place a GaAs modulator with its own source in each T/R module or subarray of the phased array antenna rather than feeding the optical carrier to the module via an additional optical input.

The balanced receiver link architecture demonstrated in this paper may also yield 10 dB improvements in the noise figures of external modulation links at the higher microwave frequency bands. If external modulation is shown to impart

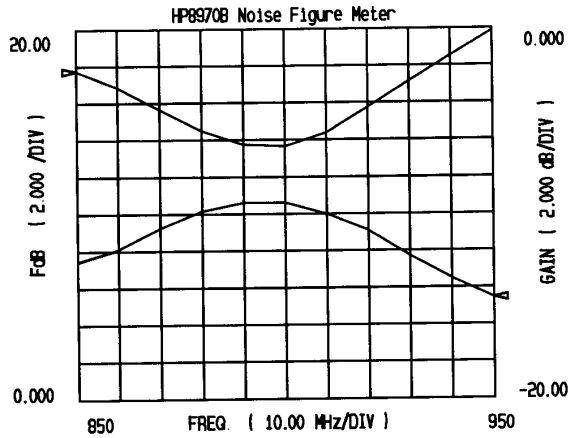

Figure 3 Measured gain and noise figure of experimental external modulation link. At 900 MHz, $G=-9.5 \text{ dB}$ and $NF=13.5 \text{ dB}$.

lower cost and higher performance to the optical interconnects in a microwave phased array, the optical beamforming architectures that best leverage these advantages will gain pre-eminence.

ACKNOWLEDGMENTS

The authors wish to thank D. Hogue and M. McCabe-Bunyea for their assistance in the assembly of this fiber-optic link.

REFERENCES

- [1] Seeds, A., "Optical Beamforming Techniques for Microwave Phased-Array Antennas," *Microwave Journal*, Vol. 35, No. 7, pp. 74-83.
- [2] Zmuda, H., and E. Toughlian, "Adaptive Microwave Signal Processing: A Photonic Solution," *Microwave Journal*, Vol. 35, No. 2, pp. 58-71.
- [3] Ackerman, E., S. Wanuga, D. Kasemset, W. Minford, N. Thorsten, and J. Watson, "Integrated 6-Bit Photonic True-Time-Delay Unit for Lightweight 3-6 GHz Radar Beamformer," *1992 MTT-S Symposium Digest*, Vol. II, pp. 681-684.
- [4] Riza, N.A., "Liquid Crystal-Based Optical Control of Phased Array Antennas," *IEEE/OSA Journal of Lightwave Tech.*, Vol. 10, No. 12, Dec. 1992.

- [5] Esman, R., M. J. Monsma, J. L. Dexter, and D. G. Cooper, "Microwave True Time-Delay Modulator Using Fibre-Optic Dispersion," *Electronics Letters*, Vol. 28, No. 20, pp. 1905-1907, Sept. 1992.
- [6] Ackerman, E., D. Kasemset, and S. Wanuga, "External Modulation L-Band Link with 117 dB Spurious-Free Dynamic Range," *Microwave Journal*, Vol. 34, No. 9 (September 1991), pp. 158-164.
- [7] Betts, G. E., L. M. Johnson, C. H. Cox III, and S. D. Downey, "High-Performance Optical Analog Link Using External Modulator," *IEEE Photonics Technology Letters*, Vol. 1, No. 11, November 1989, pp. 404-406.
- [8] Betts, G. E., L. M. Johnson, and C. H. Cox, "High-Sensitivity Bandpass RF Modulator in LiNbO₃," *Proc. SPIE* Vol. 993: Integrated Optical Circuit Engineering VI (1988), pp. 110-116.
- [9] Ackerman, E., D. Kasemset, S. Wanuga, D. Hogue, and J. Komiak, "A High-Gain Directly Modulated L-Band Microwave Optical Link," *1990 MTT-S Symposium Digest*, Vol. 1, pp. 153-155.
- [10] Daryoush, A. S., E. Ackerman, R. Saedi, R. Kunath, and K. Shalkhauser, "High-Speed Fiber-Optic Links for Distribution of Satellite Traffic," *IEEE Trans. Microwave Theory Tech.*, Vol. 38, No. 5, May 1990, pp. 510-517.
- [11] Wanuga, S., E. Ackerman, D. Kasemset, and J. Komiak, "Integrated Microwave Optoelectronic Transceivers for Lightweight Fiber-Optic Harnesses and Remote Microwave Signal Transmission," *1991 GOMAC Conf. Digest*, November 1991, pp. 477-480.
- [12] Ackerman, E., D. Kasemset, S. Wanuga, R. Boudreau, J. Schlafer, and R. Lauer, "A Low-Loss Ku-Band Directly Modulated Fiber-Optic Link," *IEEE Photonics Technology Letters*, Vol. 3, No. 2, February 1991, pp. 185-187.
- [13] Betts, G. E., C. H. Cox III, and K. G. Ray, "20-GHz Optical Analog Link Using an External Modulator," *IEEE Photonics Technology Letters*, Vol. 2, No. 12, December 1990.
- [14] Madjar, A., and O. Malz, "A Balanced Fiberoptic Communication Link Featuring Laser RIN Cancellation," *1992 IEEE MTT-S Digest*, June 1992, pp. 563-566.
- [15] Wanuga, S., E. Ackerman, J. MacDonald, J. Prince, and D. Hogue, "A High Performance Fiber-Optic Link Using a Y Balanced EO Modulator and Various Laser Sources," *1992 GOMAC Conf. Digest*, November 1992, pp. 305-308.