

PSI-0204 SERIES PSI-204-11 CHIP-SCALE BIAS CONTROLLER

PRODUCT DESCRIPTION

The PSI-0204-11 chip-scale optical modulator bias controller (MBC) offers comprehensive control of external optical modulators from a single, small form factor circuit board. When operated with lithium niobate (LiNbO₃) modulators, the PSI-0204-11 provides automatic or manual bias control. Users may select automatic tracking of Quad +, Quad -, Minimum or Maximum bias points as shown in Figure 1.

Operation at an externally set manual bias point may also be selected.

Using a dither tone, the PSI-0204-11 tracks a user selected operating point to within +/- 1° at 1% dither of V_π when operating at quadrature. Dither frequency is set at 1 KHz and dither amplitude is user defined between 20 and 200mVpp. Bias point accuracy is maintained over a wide operating temperature range of 0° to +50° C. Using a common photodetector, bias point accuracy is easily maintained over a 10dB range of optical power. Wider dynamic range controllers are available upon request.

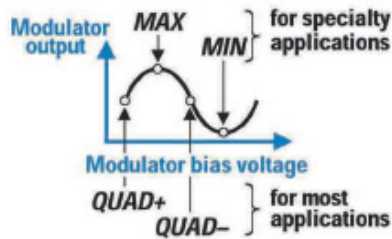
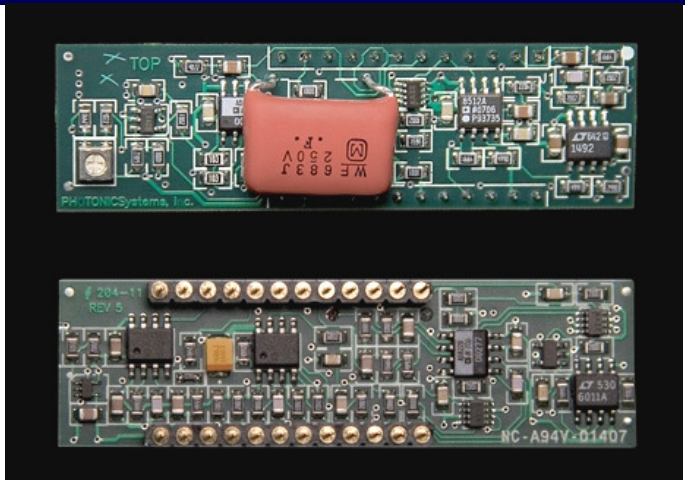

Figure 1- Modulator Transfer Function

Designed for easy integration into the user's optical system, these controllers maintain constant bias point operation by compensating for drift in a modulator's transfer function. An external modulation fiber optical transmitter is shown in Figure 2 to illustrate how the controller is typically used. A dither tone is applied to the modulator bias voltage and sampled at the modulator optical output. Through use of an optical coupler and photodetector, a portion of the transmitted light is detected and fed to the MBC. User settings determine bias point and amplitude.

Beyond standard specifications, PSI can modify the PSI-0204-11 to meet the exact requirements of your application, such as specific dither frequency, wide temperature range or very large optical input range. Smaller package sizes are offered for operation at a single bias point; other designs may also result in micro-miniature packages.

An optional evaluation kit is available to aid with design-in and proof of concept activities. The evaluation board provides a convenient means to power, control and test the MBC in a laboratory setting. Electrical connections are provided through either a DB9 or Molex plug. An optical photodetector completes the feedback loop. Included in the kit are an evaluation board with photodetector, AC power adapter and an MBC device.



FEATURES AND BENEFITS

- ✓ DITHER BASED CONTROL COMPATIBLE WITH MOST OPTICAL MODULATORS
- ✓ ADJUSTABLE DITHER AMPLITUDE: 20 TO 200MVPP
- ✓ POWER SUPPLY RANGE: +/-12 TO +/-18VOLTS
- ✓ LOW OPERATING CURRENT: <12MA TYPICAL
- ✓ SMALL SIZE: 2.5"X 0.7", 24PIN, 0.6" WIDTH DIP
- ✓ CUSTOMIZED DESIGNS AVAILABLE IN MICRO-SIZED PACKAGES
- ✓ EVALUATION KIT AVAILABLE FOR SIMPLE TEST AND DESIGN

Applications

- Modulator design
- Integrated Modulator/Transmitters
- Fiber optic component evaluation
- Photonic Test Systems
- Spectroscopy systems
- Analog communications systems

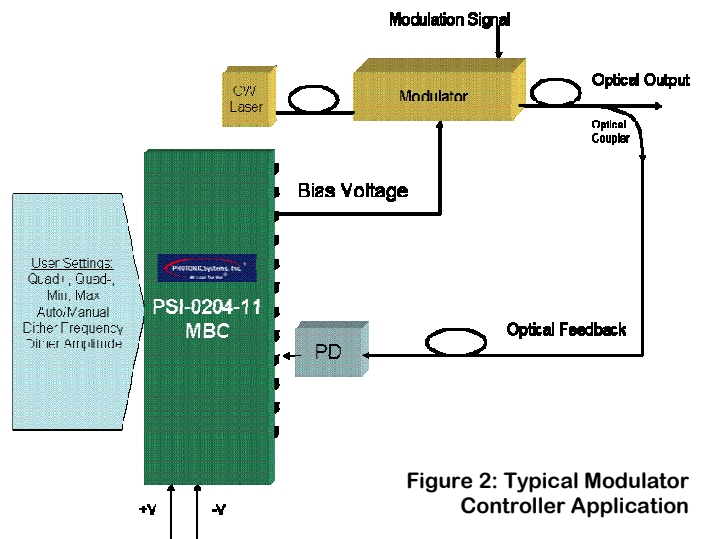
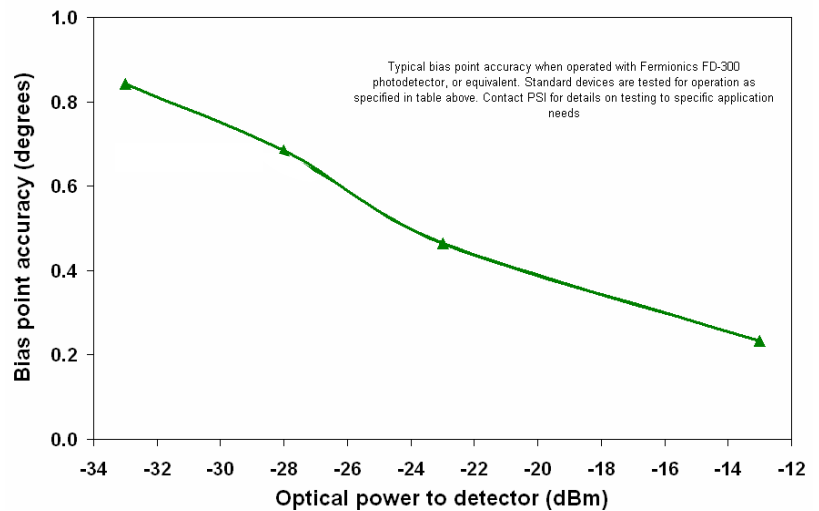
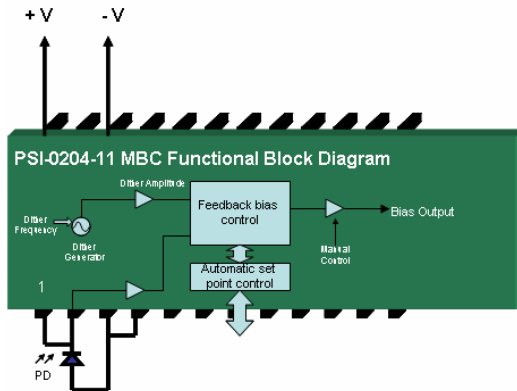
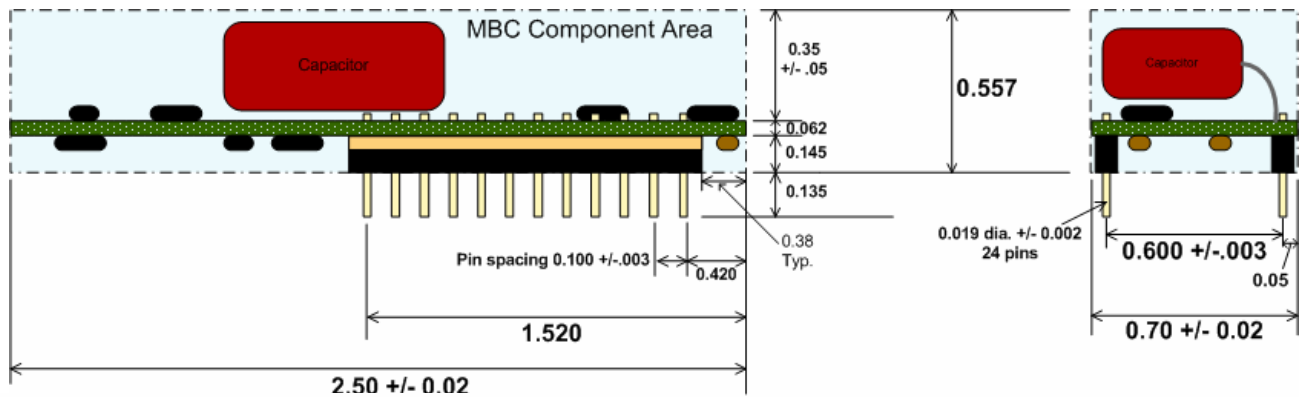

Figure 2: Typical Modulator Controller Application

Specifications

Parameter	Typical Value	Units
Modulating Signal	Analog small or large signal or DPSK	—
Modulators Supported	LiNbO ₃	—
Modulator/Bias-T Load Capacitance	< 0.2	μ F
Output DC Bias Port Impedance	100	ohms
Output DC Bias Voltage	0.3 less than supply voltage	Volts
Dither Frequency	1	KHz
Dither Amplitude	20 to 200; user defined	mVpp
Bias Point Error @Quad + or Quad - point, 5 to 50 μa photo detector current ¹	1 @1% dither of V _π	degrees
Bias Point Error @Max or Min point, 10 to 100 μa photo detector current ¹	< 0.1	degrees
DC Power Supply	+/- 12 to +/-18	Volts
DC Operating Current	< 12	mA
Operating Temperature Range	0 to +50	°C
MBC Board Dimensions	2.5 x 0.7 (6.4 x 1.7cm) ; 24 pin dual in-line package, 0.6" width	inches

1. Equivalent to -23 to -13 dBm of optical power (at quadrature) applied to Fermionics FD-300 or equivalent photo detector. Wider dynamic range controllers available at additional cost; contact PSI for details.



Device Function and Pin Descriptions

Pin	Function	Description
1	PD Bias	Provides internally generated bias voltage for photodetector. Normally connected together with Pin 2 to the PD cathode.
2	PD Cathode	Photodetector cathode connection. Normally connected to Pin 1 for PD bias.
3	PD Anode (Common)	Photodetector anode connection.
4	PD Anode (Common)	Photodetector anode connection.
5	Master	Output of PD preamplifier. Normally connected to pin 6. May be used for control of slaved bias controllers.
6	Slave	Input to dither detection circuitry. Normally connected to pin 5. May be used for control from a master bias controller.
7	Ground	Device Ground
8	Intg. In	Control loop integrator input. Normally unused, this input allows for modification of the bias control response time.
9	-Intg. -B	Control loop integrator output. Normally connected to pin 10, this output allows for modification of the bias control response time.
10	+Intg. +B	Control loop integrator output. Normally connected to pin 9, this output allows for modification of the bias control response time.
11	Bias Out	Bias output
12	Manual Bias In	Input for control of bias in manual mode. Input voltage ranges from -V to +V for control of bias voltage over Max to Min.
13	Dither Out- Lo Adj	Low dither voltage output. May be used for fine adjustment of dither amplitude. Normally not used.
14	Dither In	Dither input. Normally connected to pin 15 through a user selectable resistance to set dither amplitude. May be used to implement adjustable dither in conjunction with pin 15.
15	Dither Out Adj	Dither generator output. Normally connected to pin 14 through a user selectable resistance to set dither amplitude. May be used to implement adjustable dither in conjunction with pin 14.
16	Auto Bias Select 2	Input to set auto bias point in conjunction with pin 17. See table 1 below. Device employs internal 200k pull up resistor.
17	Auto Bias Select 1	Input to set auto bias point in conjunction with pin 16. See table 1 below. Device employs internal 200k pull up resistor.
18	Freq. Adj (future use)	No connection- Dither frequency control in future release; not supported at this time.
19	+Vlog Out	4.5 volt reference output. Normally not used.
20	Reset	Control loop reset input. Ground for normal operation, allow high for reset; device employs 200k pull up resistor.
21	Auto/Manual Select	Selects Automatic or manual bias point control. Connect to ground for automatic control; open for manual control. Device employs internal 200k pull up resistor.
22	-V	Negative power supply connection. Acceptable range from -4.75 to -18 volts
23	Ground	Device Ground
24	+V	Positive power supply connection. Acceptable range from 4.75 to 18 volts

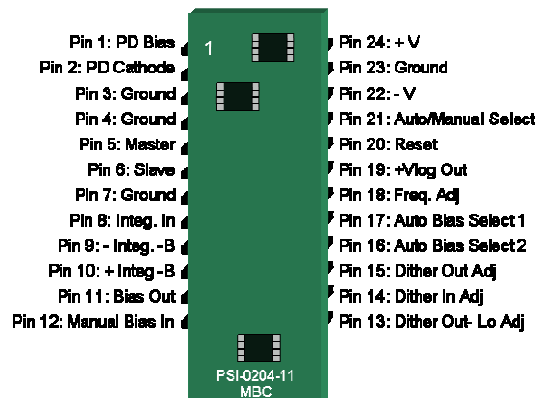

MBC Pin	Pin 17	Pin 16
Bias Point		
Q+	Open	Open
Q-	Ground	Open
Max	Open	Ground
Min	Ground	Ground

Table 1: Auto bias control point settings.

PRODUCT DESCRIPTION

The PSI-0204-99 optical modulator bias controller (MBC) evaluation kit provides a complete laboratory solution for evaluation of the PSI-0204-11 chip-scale MBC. The chip-scale controller provides control of external optical modulators from a single, small form factor circuit board. When operated with lithium niobate (LiNbO₃), modulators, the PSI-0204-11 provides automatic or manual bias control. Users may select automatic tracking of Quad +, Quad -, Minimum or Maximum bias points as shown in Figure 1. Operation at an externally set manual bias point may also be selected.

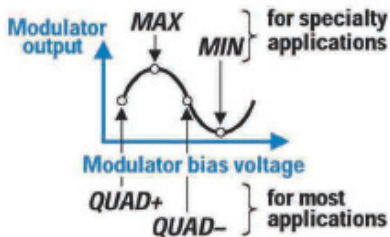

Figure 1– Modulator Transfer Function The chip-scale device evaluation board provides a simple

means to make all necessary electrical and optical connections to an MBC under evaluation. A 24 pin socket on top of the board hosts the device under test. All electrical and optical connections are made to the device including power, user-defined settings and bias voltage output. An on-board photodetector completes the optical feedback loop from a user's modulator and laser system. Controls are provided to set manual bias point, automatic bias point, bias offset, dither amplitude and dither frequency. Push buttons allow for temporary hold of a bias point, dither disable and forced reset. A bias monitor port is provided as are connections through either a D-type or Molex connector. The kit is shipped complete with a sample MBC, AC power supply, and connectors.

ABOUT THE PSI-0204-11 CHIP-SCALE MBC

Designed for easy integration into the user's optical system, these controllers maintain constant bias point operation by compensating for drift in a modulator's transfer function. An external modulation fiber optical transmitter is shown in Figure 2 to illustrate how the controller is typically used. Through use of an optical coupler and photodetector, a portion of the transmitted light is detected and fed to the MBC. The dither tone is applied to the bias voltage output and sampled as a control mechanism. User settings determine bias point selection, dither frequency and amplitude.

Beyond standard specifications, PSI can modify the PSI-0204-11 to meet the exact requirements of your application. Smaller package sizes are offered for operation at a single bias point; other designs may also result in micro-miniature packages.

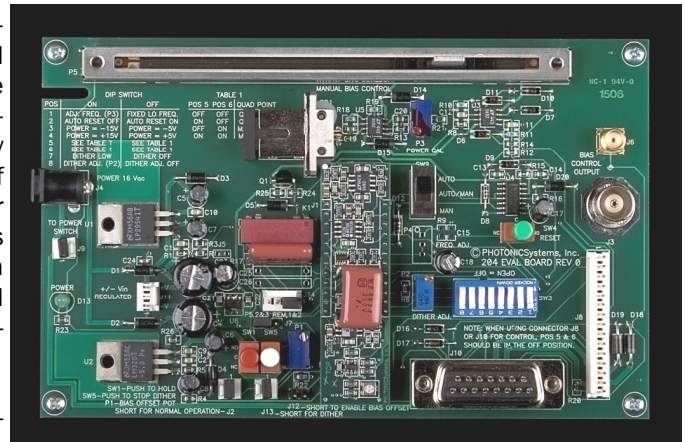

FEATURES AND BENEFITS

- ✓ COMPLETE EVALUATION KIT FOR PSI-0204-11 MODULATOR BIAS CONTROLLER
- ✓ INCLUDES ALL CONTROL COMPONENTS TO TEST MBC WITH YOUR APPLICATION
- ✓ DITHER BASED CONTROL COMPATIBLE WITH MOST OPTICAL MODULATORS
- ✓ INCLUDES SAMPLE MBC, AC POWER SUPPLY AND DC ELECTRICAL CONNECTORS.

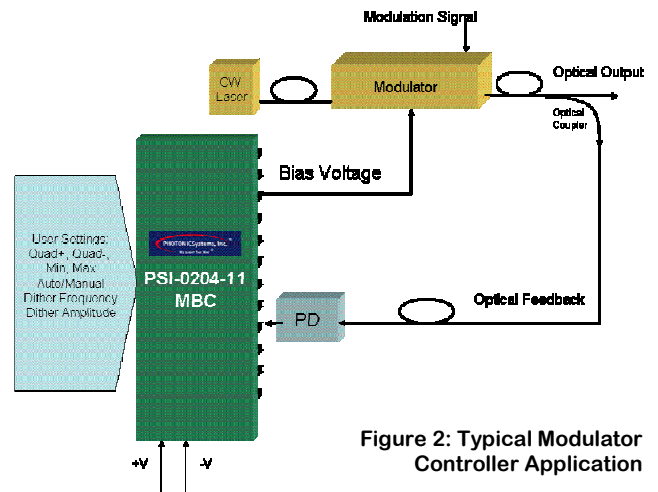
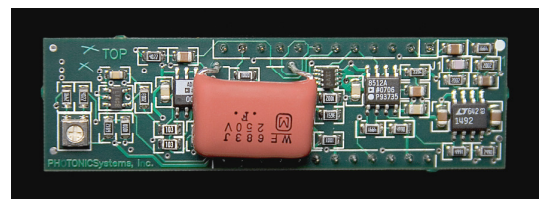

Figure 2: Typical Modulator Controller Application